

# Aluminum Replacement Windows

Light Commercial • Thermally Broken • Custom Built

- Custom Built, Easy to Install & Clean
- Strong, Durable & Engineered to Save Money
- Lifetime Limited Residential Warranty

(ask about our commercial application warranty details)

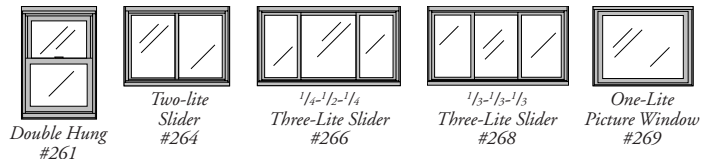

## Double Hung

Model #261

(shown with optional sill and jamb panning)

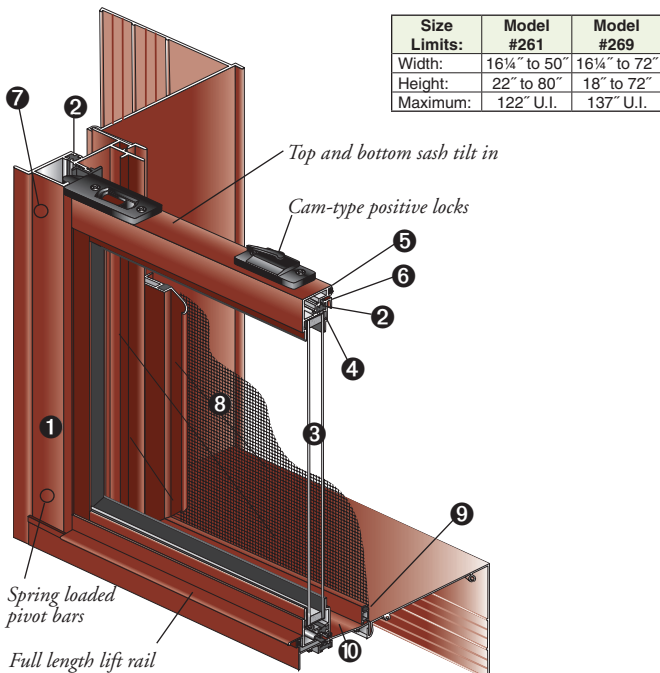

Size Limits:	Model #261	Model #269
Width:	16¼" to 50"	16¼" to 72"
Height:	22" to 80"	18" to 72"
Maximum:	122" U.I.	137" U.I.

## Two-Lite Slider

Model #264

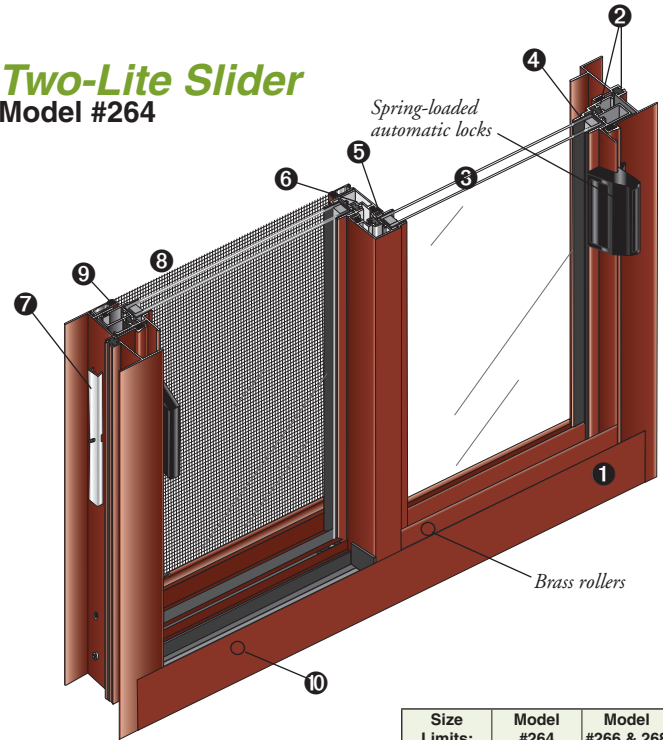

Size Limits:	Model #264	Model #266 & 268
Width:	18" to 80"	48" to 120"
Height:	16½" to 64"	16½" to 64"
Maximum:	144" U.I.	

## Standard Features & Benefits

- 1 Baked on polyester finish backed by a Lifetime Limited warranty.
- 2 Thermally broken sash and main frame reduces conduction of heat and cold.
- 3 ¾" *ComforTech*™ warm edge glazing system reduces heating and cooling bills.
- 4 Wrap around marine glazing seals glass firmly and makes replacement easy.
- 5 Barrier-fin-type weatherstripping reduces air and dust infiltration.
- 6 Interlocking meeting rails
- 7 Adjustable steel jamb shims
- 8 Fiberglass half screen
- 9 Extruded aluminum screen frame adds strength.
- 10 The sill's extra height and slope protects against water infiltration.

# Options and Specifications:

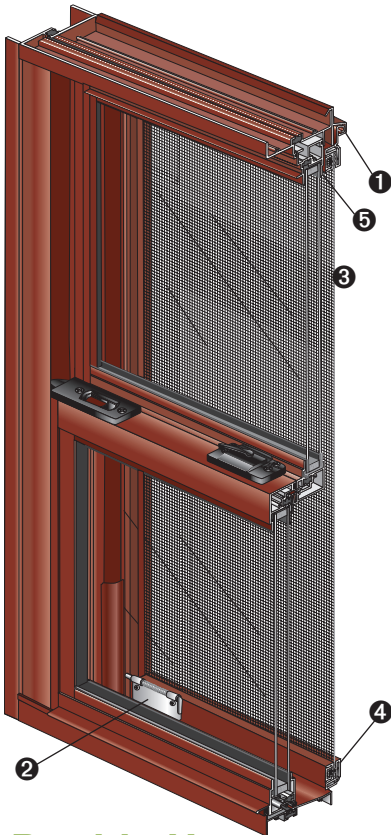

## Double Hung Model #261

(shown with optional #088 DuraGuard Screen)

### Optional DuraGuard Screens:

- 1 Extruded continuous top hinge system
- 2 Dual spring loaded stainless steel latches
- 3 12 x 12 mesh x .023" diameter black stainless steel screen
- 4 Heavy-duty extruded aluminum frame
- 5 Contoured design with "Draw Tight" screen system
- 6 No exposed exterior fasteners

Optional  
Factory Mounted  
DuraGuard Screen  
with .023 Gauge  
Stainless Steel Screen  
Available on  
#261 & #264  
Models

### Options:

- Obscure Glass
- Double Strength Glass
- **Comfortech™ DLA\***
- Tempered Glass
- Tinted Glass
- Oriel Style
- Colonial, Prairie, Cottage & Diamond Style Painted Grids
- Colonial, Prairie & Cottage Style Pencil Brass Grids
- Full Screens
- Aluminum Screen Wire
- Panning and Snap-on Trim

\* High Performance Low-E glass with Argon

Grid Colors	White	Café Cream	Tudor Brown	Rustic Bronze	Sandpiper Beige	Sandstone	Mountain Berry	Forest Green
Colonial, Prairie & Cottage Style Flat Grids	●	●	●	●	●	●		
Colonial, Prairie & Cottage Style Contour Grids	●	●	●	●	●	●	●	●
Diamond Style Flat Grids	●	●	●	●	●			

To select finish, refer to our color selector for accurate color representation.  
Ask About Color Coordinated Storm Doors & Entry Doors

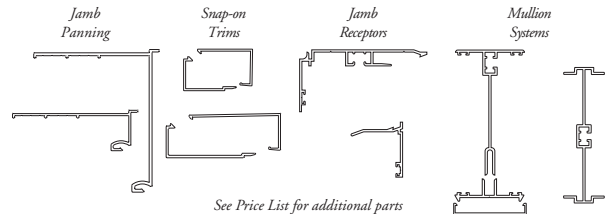

See Price List for additional parts

### Featured Colors



### Limited Colors



• Additional 2 week lead time required when using Limited Colors on Aluminum Windows.

## Test Results:

### Structural Test

Air Leakage Rate:

Maximum Water Pressure Achieved:

Structural Pressure:

Overall Product Rating:

### Thermal Test

Comfortech™ DLA with Low-E Storm Unit:

Comfortech™ DLA without Storm Unit:

SCFM = Standard Cubic Foot per Minute PSF = Pounds per Square Foot DH = Double Hung HS = Horizontal Slider C = Commercial F = Fixed ft² = Square Foot

### 261 Double Hung

0.04 SCFM/ft²

6.0 PSF

52.5 PSF

DH - C35

U - Factor:

0.30

0.42

### 264 Two-Lite Slider

0.03 SCFM/ft²

5.25 PSF

52.5 PSF

HS - C35

U - Factor:

0.28

0.42

### 269 Picture Window

0.01 SCFM/ft²

9.75 PSF

97.5 PSF

F-C65

U - Factor:

0.23

0.36



www.proviadoor.com



Distributed by: